

## Three-phase motors Aluminium housing

Type		SA2 71B4-405 AA
Design output	[kW]	0.37
Design torque	[Nm]	2.7
Class IE		IE2-72.7%
Efficiency determination		EN 60034-2-1
Duty type		S1
Design frequency	[Hz]	50
Design speed	[rpm]	1330
Voltage	[V]	230/400
Connection		D / Y
Current	[A]	1.7 / 1.0
Relative pull-in current		6.1
Relative starting torque		2.8
Relative pull-out torque		3.1
Efficiency 100 / 75 / 50 %	[%]	72.7 / 72.4 / 71.9
Power factor		0.74
Th. cl.		155 (F/B)
Coolant temperature	[°C]	-20°C ... +40°C
Altitude above sea level	[m]	1000
Degree of protection IP		IP 55
Moment of inertia	[kgm <sup>2</sup> ]	0.00124
Motor weight	[kg]	7.2
Bearing D-side		6202 2RS/C3
Bearing N-side		6202 2RS/C3
Relubrication interval	[h]	-
Grease type		-
Grease amount	[g]	-
A-sound pressure level L <sub>WA</sub>	[dB]	64.0
<b>Options:</b>		
Terminal box		Standard
Position of terminal box		On the top
Cable gland		Brass cable glands
Position of cable entry		Right
Shaft		Standard
Bearing		Easy bearing arrangement
Special information about the bearing		SKF bearing
Winding protection		-
Limit values to vibration velocity		Class A
Balancing		with half key
Colour		RAL 7030
Delivery conditions and/or official regulations		IEC / EN 60034-1

# Data sheet

## IM B3



## IM B35

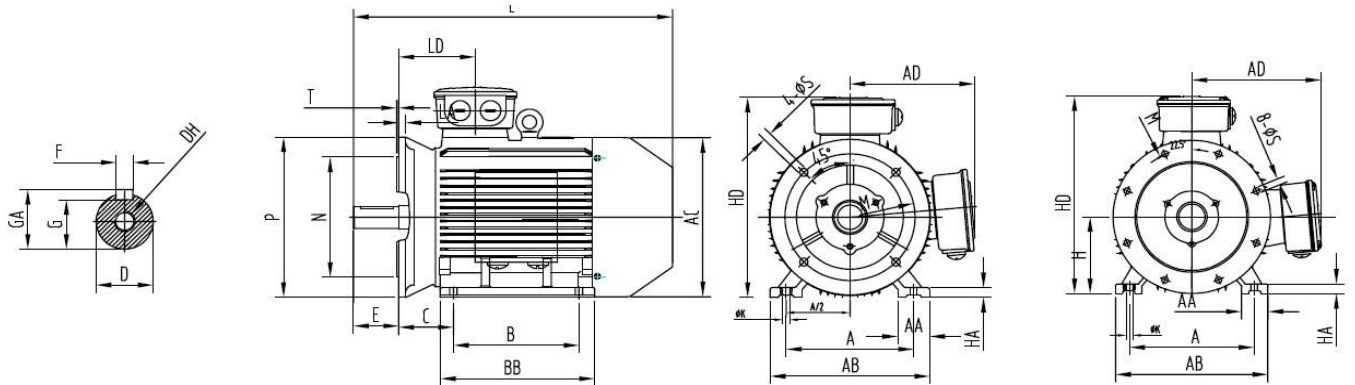

## IM B5



A	B	B <sup>1</sup>	C	D	E	F	G	H	K	DH	GA	AA	AB
112	90	-	45	14	30	5	11	71	10	M5x13	16	32	132

AC	AD	HA	HD	BB	LD	L	M	N	P	S	T	LA
139	117	10	188	105	68	255	130	110	160	4 x ø10	3.5	-

# Data sheet

## IM B14



## IM B34



A	B	B <sup>1</sup>	C	D	E	F	G	H	K	DH	GA	AA	AB
112	90	-	45	14	30	5	11	71	10	M6x13	16	32	132

	AC	AD	HA	HD	BB	LD	L	M	N	P	S	T	LA
B14C	139	117	10	188	105	68	255	85	70	105	4 x M6	2.5	-
B14B	139	117	10	188	105	68	255	115	95	140	4 x M8	3	-