

Three-phase motors Cast iron housing

Type		SC2 280S4-695 AB
Design output	[kW]	75
Design torque	[Nm]	482
Class IE		IE2-94.5%
Efficiency determination		EN 60034-2-1
Duty type		S1
Design frequency	[Hz]	50
Design speed	[rpm]	1485
Voltage	[V]	400/690
Connection		D / Y
Current	[A]	133.0 / 77.1
Relative pull-in current		6.5
Relative starting torque		2.4
Relative pull-out torque		3.1
Efficiency 100 / 75 / 50 %	[%]	94.5 / 93.9 / 93.3
Power factor		0.87
Th. cl.		155 (F/B)
Coolant temperature	[°C]	-20°C ... +40°C
Altitude above sea level	[m]	1000
Degree of protection IP		IP 55
Moment of inertia	[kgm ²]	1.04500
Motor weight	[kg]	581
Bearing D-side		6316/C3
Bearing N-side		6316/C3
Relubrication interval	[h]	4900
Grease type		ESSO BEACON 3 / SKF LGMT3
Grease amount	[g]	33
A-sound pressure level L _{WA}	[dB]	83.0

Options:

Terminal box	Standard
Position of terminal box	On the top
Cable gland	Brass cable glands
Position of cable entry	Right
Shaft	Standard
Bearing	Relubrication device, heavy bearing arrangement
Special information about the bearing	SKF bearing
Winding protection	1 set PTC resistors
Limit values to vibration velocity	Class A
Balancing	with half key
Colour	RAL 7030

Delivery conditions and/or official regulations	IEC / EN 60034-1
---	------------------

Data sheet

IM B3

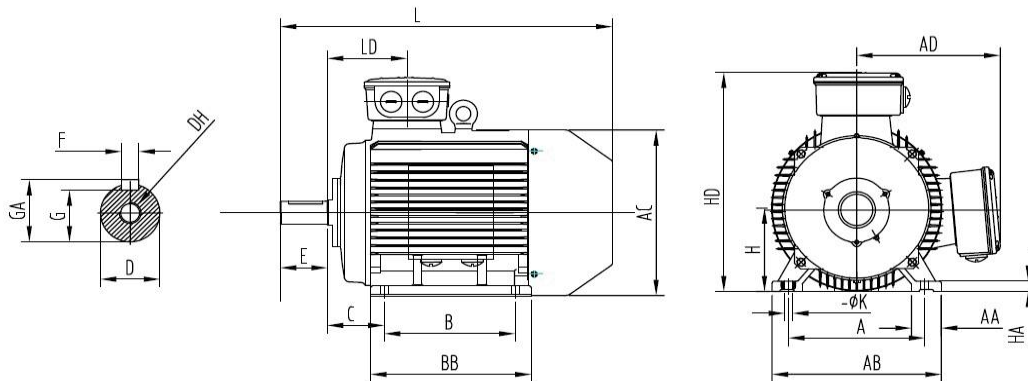

IM B35

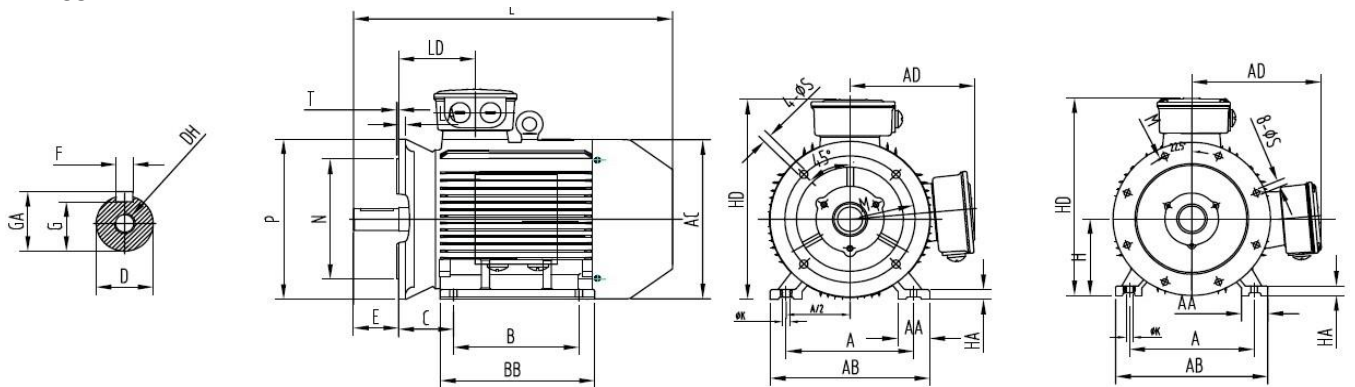

IM B5

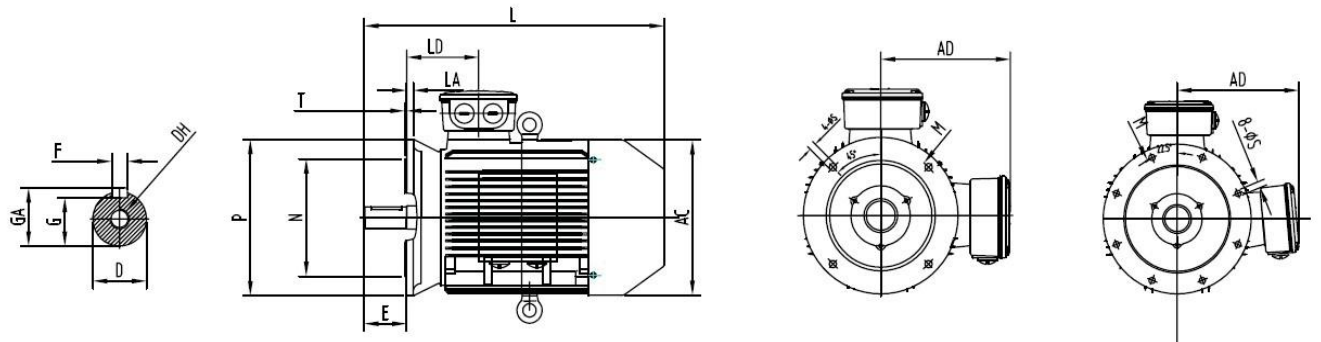

A	B	B ¹	C	D	E	F	G	H	K	DH	GA	AA	AB
457	368	-	190	75	140	20	67.5	280	24	M20x42	79.5	85	550

AC	AD	HA	HD	BB	LD	L	M	N	P	S	T	LA
550	410	35	698	490	215	978	500	450	550	8 x ø18.5	5	22