

Three-phase motors Cast iron housing

Type		SC2 225M4-695 AB
Design output	[kW]	45
Design torque	[Nm]	290
Class IE		IE2-94.2%
Efficiency determination		EN 60034-2-1
Duty type		S1
Design frequency	[Hz]	50
Design speed	[rpm]	1480
Voltage	[V]	400/690
Connection		D / Y
Current	[A]	80.6 / 46.7
Relative pull-in current		7.1
Relative starting torque		2.4
Relative pull-out torque		3.2
Efficiency 100 / 75 / 50 %	[%]	94.2 / 93.3 / 92.9
Power factor		0.87
Th. cl.		155 (F/B)
Coolant temperature	[°C]	-20°C ... +40°C
Altitude above sea level	[m]	1000
Degree of protection IP		IP 55
Moment of inertia	[kgm ²]	0.45000
Motor weight	[kg]	337
Bearing D-side		6313 2RS/C3
Bearing N-side		6313 2RS/C3
Relubrication interval	[h]	-
Grease type		-
Grease amount	[g]	-
A-sound pressure level L _{WA}	[dB]	81.0
Options:		
Terminal box		Standard
Position of terminal box		On the top
Cable gland		Brass cable glands
Position of cable entry		Right
Shaft		Standard
Bearing		Easy bearing arrangement
Special information about the bearing		SKF bearing
Winding protection		1 set PTC resistors
Limit values to vibration velocity		Class A
Balancing		with half key
Colour		RAL 7030
Delivery conditions and/or official regulations		IEC / EN 60034-1

IM B3



IM B35

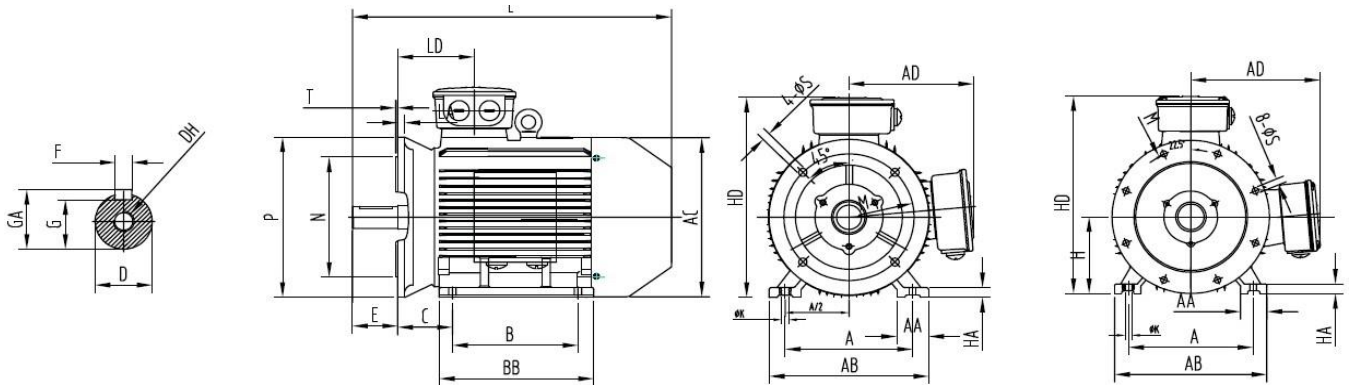

IM B5

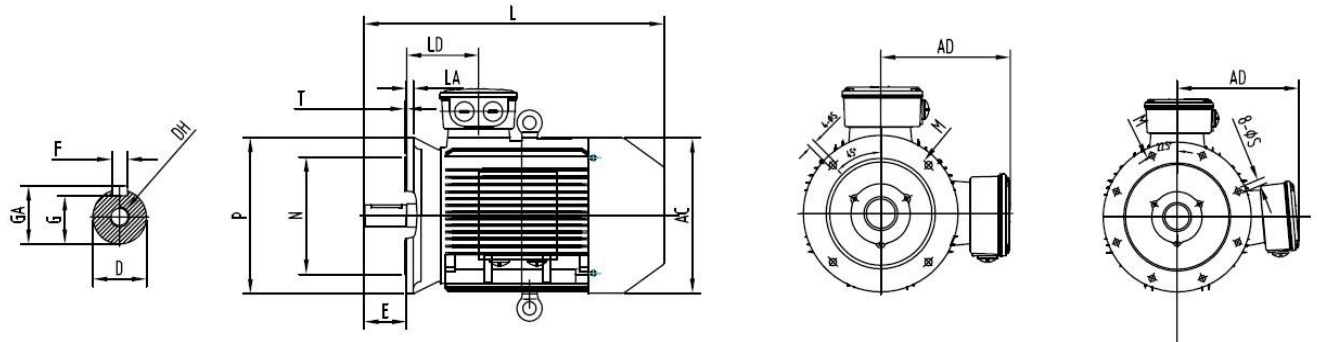

A	B	B ¹	C	D	E	F	G	H	K	DH	GA	AA	AB
356	286	311	149	60	140	18	53	225	19	M20x42	64	75	435

AC	AD	HA	HD	BB	LD	L	M	N	P	S	T	LA
470	370	28	580	395	189	845	400	350	450	8 x $\phi 18.5$	5	20