

Three-phase motors Cast iron housing

Type		SC2 180L4-695 AB
Design output	[kW]	22
Design torque	[Nm]	142
Class IE		IE2-91.6%
Efficiency determination		EN 60034-2-1
Duty type		S1
Design frequency	[Hz]	50
Design speed	[rpm]	1465
Voltage	[V]	400/690
Connection		D / Y
Current	[A]	39.9 / 23.1
Relative pull-in current		6.9
Relative starting torque		2.1
Relative pull-out torque		3.1
Efficiency 100 / 75 / 50 %	[%]	91.6 / 91.4 / 91.2
Power factor		0.88
Th. cl.		155 (F/B)
Coolant temperature	[°C]	-20°C ... +40°C
Altitude above sea level	[m]	1000
Degree of protection IP		IP 55
Moment of inertia	[kgm ²]	0.13600
Motor weight	[kg]	193
Bearing D-side		6311 2RS/C3
Bearing N-side		6311 2RS/C3
Relubrication interval	[h]	-
Grease type		-
Grease amount	[g]	-
A-sound pressure level L _{WA}	[dB]	81.0
Options:		
Terminal box		Standard
Position of terminal box		On the top
Cable gland		Brass cable glands
Position of cable entry		Right
Shaft		Standard
Bearing		Easy bearing arrangement
Special information about the bearing		SKF bearing
Winding protection		1 set PTC resistors
Limit values to vibration velocity		Class A
Balancing		with half key
Colour		RAL 7030
Delivery conditions and/or official regulations		IEC / EN 60034-1

Data sheet

IM B3

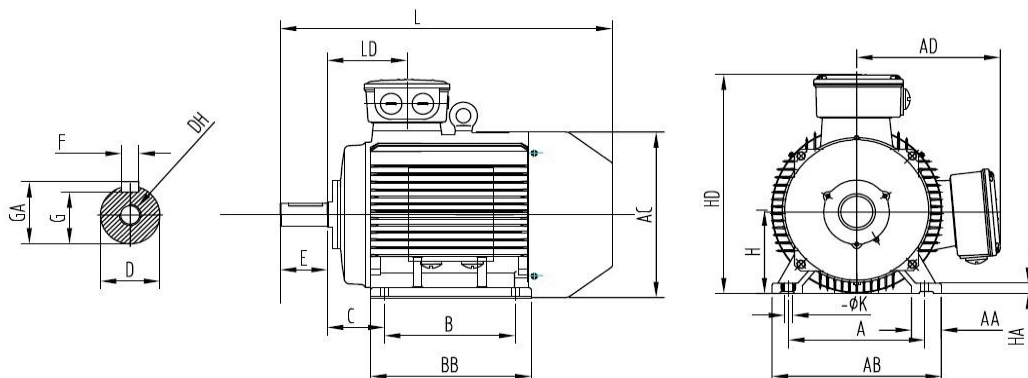

IM B35

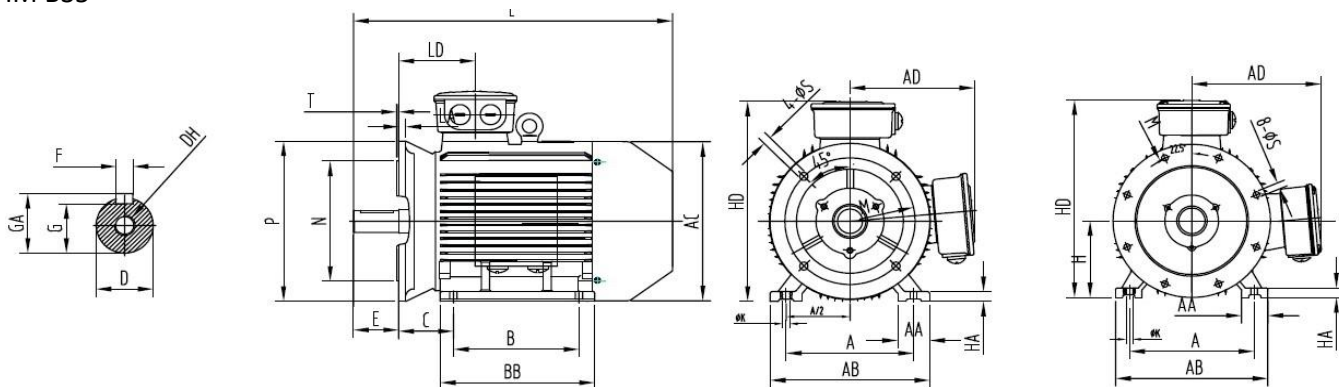

IM B5

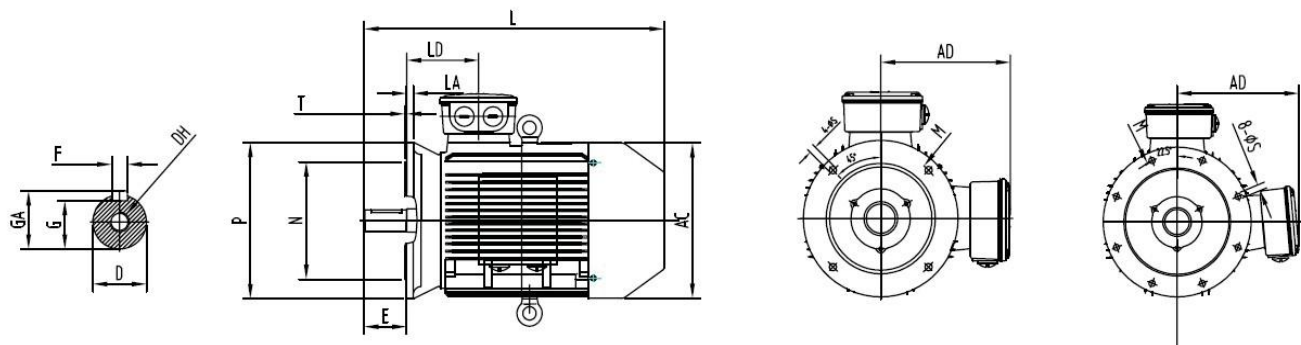

A	B	B ¹	C	D	E	F	G	H	K	DH	GA	AA	AB
279	241	279	121	48	110	14	42.5	180	15	M16x36	51.5	70	355

AC	AD	HA	HD	BB	LD	L	M	N	P	S	T	LA
380	310	22	470	355	161	720	300	250	350	4 x ϕ 18.5	5	15