

Three-phase motors Cast iron housing

Type		SC2 355L2-695 AB
Design output	[kW]	315
Design torque	[Nm]	1009
Class IE		IE2-96.4%
Efficiency determination		EN 60034-2-1
Duty type		S1
Design frequency	[Hz]	50
Design speed	[rpm]	2980
Voltage	[V]	400/690
Connection		D / Y
Current	[A]	519.0 / 300.9
Relative pull-in current		7.8
Relative starting torque		1.7
Relative pull-out torque		4.1
Efficiency 100 / 75 / 50 %	[%]	96.4 / 95.9 / 95.1
Power factor		0.91
Th. cl.		155 (F/B)
Coolant temperature	[°C]	-20°C ... +40°C
Altitude above sea level	[m]	1000
Degree of protection IP		IP 55
Moment of inertia	[kgm ²]	3.84900
Motor weight	[kg]	1850
Bearing D-side		NU319E/C3
Bearing N-side		6319/C3
Relubrication interval	[h]	500 / 1300
Grease type		ESSO BEACON 3 / SKF LGMT3
Grease amount	[g]	51
A-sound pressure level L _{WA}	[dB]	99.0
Options:		
Terminal box		Standard
Position of terminal box		On the top
Cable gland		Brass cable glands
Position of cable entry		Right
Shaft		Standard
Bearing		Relubrication device, heavy bearing arrangement
Special information about the bearing		SKF bearing
Winding protection		1 set PTC resistors
Limit values to vibration velocity		Class A
Balancing		with half key
Colour		RAL 7030
Delivery conditions and/or official regulations		IEC / EN 60034-1

Data sheet

IM B3

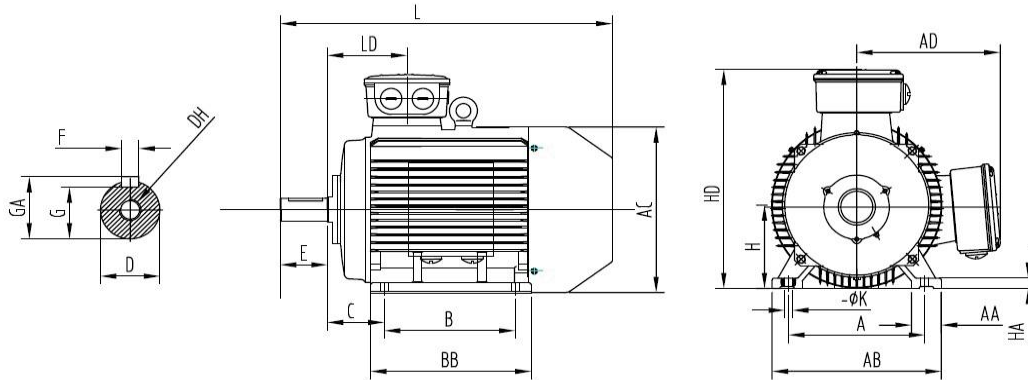

IM B35

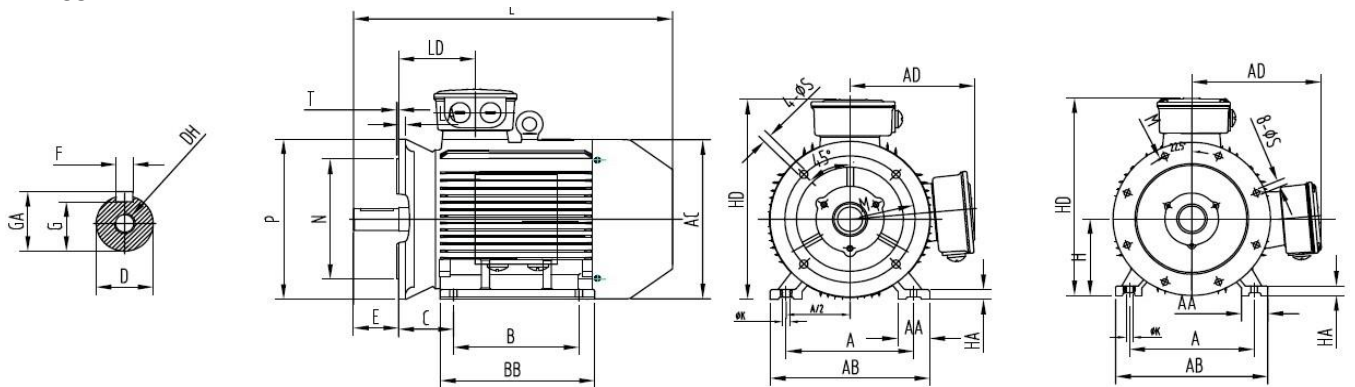

IM B5

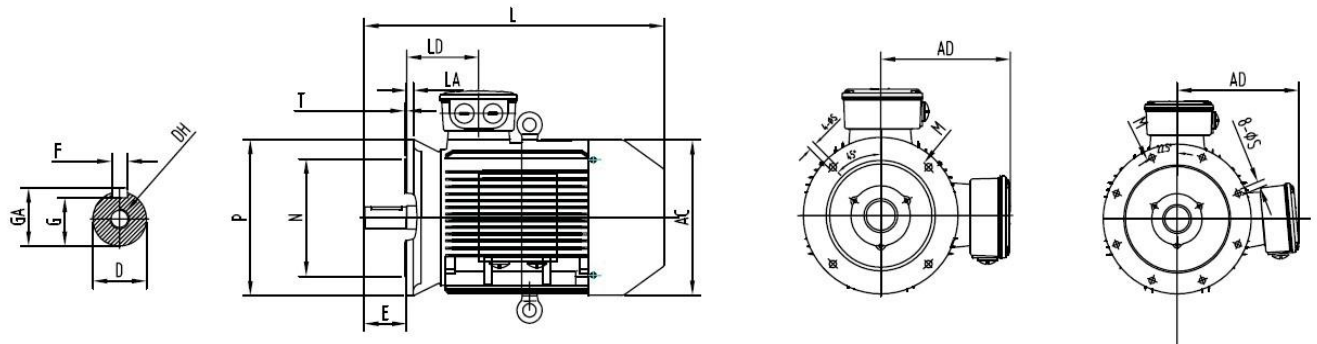

A	B	B ¹	C	D	E	F	G	H	K	DH	GA	AA	AB
610	560	630	254	75	140	20	67.5	355	28	M20x46	79.5	120	730

AC	AD	HA	HD	BB	LD	L	M	N	P	S	T	LA
720	700	52	1065	760	284	1495	740	680	800	8 x ø24	6	25